

Guidelines for the right application of plastic hinges

The following guidelines help you to choose the convenient type and the right number of hinges according to the door to be hinged. Technical designers should consider the values **Er**, **Ea**, **E90** reported in the table of every plastic hinge. Maximum working load (**Er**, **Ea**, **E90**) is the value at which elastic deformation remains neglectable during functioning. Load at breakage (**Rr**, **Ra**, **R90**) should be used for safety verification, if required.

In case of use of CFN. and CFO. hinges, considering the geometry and the structure of such elements, **E90** value is not to be taken into consideration. So the conditions here under reported, where **E90** appears, are not valid.

Hinged door on a vertical axis

These are the three conditions to be verified:

$$[(P \cdot D_1) + (P_1 \cdot D_2)] / D_3 \leq E_r \quad \text{with closed door}$$

$$(P + P_1) / N \leq E_a$$

$$[(P \cdot D_1) + (P_1 \cdot D_2)] / D_3 \leq E_{90} \quad \text{with } 90^\circ \text{ open door } (*)$$

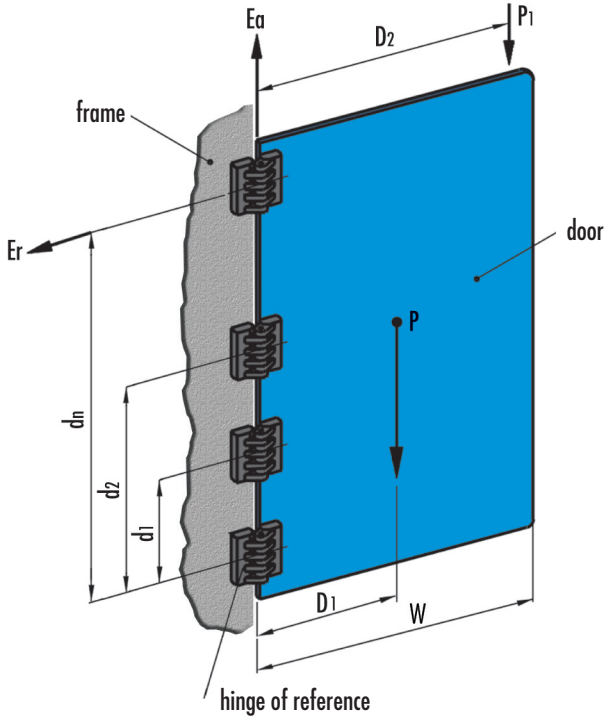

Hinged door on a horizontal axis

These are the two conditions to be verified:

$$(P + P_1) / N \leq E_r \quad \text{with closed door}$$

$$(P + P_1) / 2N \leq E_{90} \quad \text{with } 90^\circ \text{ open door } (*)$$

(in the case of balanced additional extra load on the door)

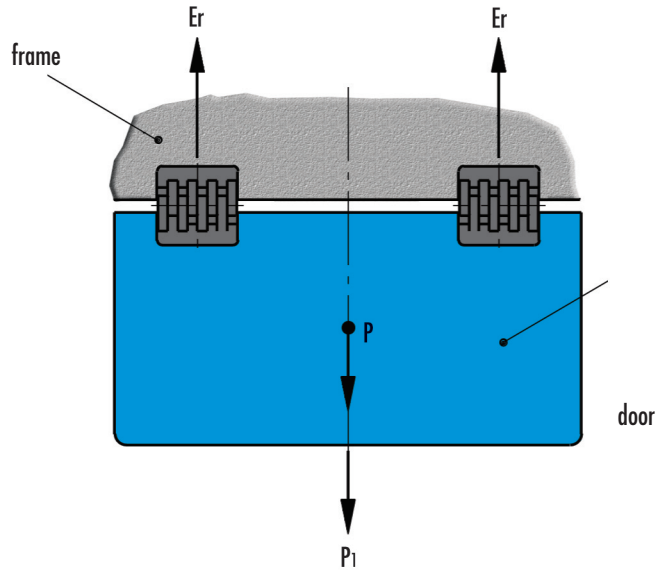

- P** = weight of the door [lbs]
- P₁** = additional extra load applied (if any) [lbs]
- N** = number of hinges
- W** = width of the door
- D₁** = distance [metres] between the centre of gravity of the door and the hinge axis. In normal conditions $D_1 = W/2$
- D₂** = distance [metres] between the hinge axis and additional extra load application point
- D₃** = sum of the distances [metres] of all the hinges from the hinge of reference ($D_3 = d_1 + d_2 + \dots + d_n$). In case of only two hinges assembled D_3 is simply the distance between them.

- Er** = maximum working radial load of the hinge [lbf]
- Ea** = maximum working axial load of the hinge [lbf]
- E90** = maximum working load with 90° open door hinge [lbf] (*).

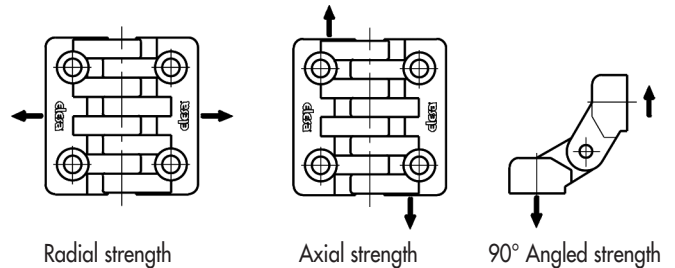

SUGGESTIONS FOR DRILLING FITTING HOLES

The proper application of hinges with moulded-in studs or bushings requires a drilling on the mounting wall with diameter not wider than 0.020 of the major diameter of the assembling screw in order to guarantee an adequate shoulder of the metal insert on the wall itself.

NOTES

All the values reported in the tables are the result of tests carried out in our laboratories under controlled temperature and humidity (73° F - 50% RH) in given conditions of use and for a relatively limited time. The technical designer should consider to use an adequate safety factor for particularly heavy conditions of use.

(*) Not valid for CFN. and CFO. series.

EXAMPLE

- P** = 294 N = **66 lbs** weight of the door
P₁ = 49 N = **11 lbs** weight of the additional extra load applied (for example: handle + lock + machine control panel fitted onto the door)
N = **2** (start evaluating two hinges)
W = 6.56 ft width of the door
D₁ = W/2 = 2/2 = **3.28 ft** distance between the centre of gravity of the door and the hinge axis.
D₂ = **3.94 ft** distance between the hinge axis and additional extra load application point
D₃ = **5.91 ft** (the example shows only the distance between the two assembled hinges).

$$[(P \cdot D_1) + (P_1 \cdot D_2)] / D_3 \leq E_r \text{ with closed door}$$

$$[(66 \cdot 3.28) + (11 \cdot 3.94)] / 5.91 = \mathbf{44 \text{ lbf} \leq E_r}$$

$$(P + P_1) / N \leq E_a$$

$$(66 + 11) / 2 = \mathbf{38.5 \text{ lbf} \leq E_a}$$

$$[(P \cdot D_1) + (P_1 \cdot D_2)] / D_3 \leq E_{90} \text{ with } 90^\circ \text{ open door}$$

$$[(66 \cdot 3.28) + (11 \cdot 3.94)] / 5.91 = \mathbf{44 \text{ lbf} \leq E_{90} (*)}$$

(*) Not valid for CFN. and CFO. series.

The right dimension can be chosen amongst the hinges with **E_r**, **E_a** and **E₉₀** values exceeding the values calculated. Always check the maximum tightening torque specification before assembly.

Hinges which satisfy the three conditions mentioned above

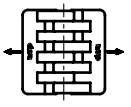
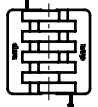
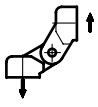
Testing method								Maximum tightening torque [ft-lb]	
		RADIAL STRENGTH		AXIAL STRENGTH		90° ANGLED STRENGTH			
Code	Description	Maximum working load E _r [lbf] [N]	Load at breakage R _r [lbf] [N]	Maximum working load E _a [lbf] [N]	Load at breakage R _a [lbf] [N]	Maximum working load E ₉₀ [lbf] [N]	Load at breakage R ₉₀ [lbf] [N]	SH/CH	B/P
422391	CFA.40 B-M4	54 240	497 2220	45 200	459 2050	22 100	164 730	-	4
422411	CFA.40 SH-4	65 290	455 2030	29 130	466 2080	63 280	340 1520	1	-
422412	CFA.40 CH-4	52 230	394 1760	31 137	403 1800	40 180	298 1330	1	-
422111	CFA.49 B-M5	99 440	688 3070	90 400	844 3770	38 170	329 1470	-	4
422113	CFA.49 B-M6	105 470	728 3250	74 330	728 3250	25 110	345 1540	-	4
422121	CFA.49 p-M5x14	81 360	441 1970	83 370	688 3070	45 200	376 1680	-	4
422131	CFA.49 SH-5	69 310	645 2880	67 300	663 2960	72 320	558 2490	1	-
422132	CFA.49 CH-5	69 310	567 2530	81 360	690 3080	56 250	363 1620	1	-
422141	CFA.49 B-M5-p-M5x14	81 360	441 1970	83 370	688 3070	45 200	329 1470	-	4
422151	CFA.49 B-M5-SH-5	63 280	645 2880	90 400	663 2960	38 170	329 1470	1	-
422152	CFA.49 B-M5-CH-5	72 320	567 2530	81 360	690 3080	38 170	329 1470	1	-
422161	CFA.49 p-M5x14-SH-5	63 280	441 1970	83 370	663 2960	45 200	376 1680	1	-
422162	CFA.49 p-M5x14-CH-5	72 320	441 1970	81 360	688 3070	45 200	363 1620	1	-
422211	CFA.65 B-M6	155 690	1270 5670	143 640	1024 4570	49 220	511 2280	-	4
422221	CFA.65 p-M6x18	103 460	1483 6620	114 510	1319 5890	49 220	715 3190	-	4
422231	CFA.65 SH-6	161 720	1404 6270	116 520	1066 4760	54 240	936 4180	2	-
422232	CFA.65 CH-6	110 490	1297 5790	114 510	1183 5280	58 260	715 3190	4	-
422241	CFA.65 B-M6-p-M6x18	103 460	1270 5670	114 510	1024 4570	49 220	511 2280	-	4
422251	CFA.65 B-M6-SH-6	155 690	1270 5670	143 640	1024 4570	49 220	511 2280	2	4
422252	CFA.65 B-M6-CH-6	110 490	1270 5670	114 510	1024 4570	49 220	511 2280	4	4
422261	CFA.65 p-M6x18-SH-6	103 460	1404 6270	114 510	1066 4760	49 220	715 3190	2	4
422262	CFA.65 p-M6x18-CH-6	103 460	1297 5790	114 510	1183 5280	49 220	715 3190	4	4
422311	CFA.97 B-M10	475 2120	4019 17940	217 970	1716 7660	132 590	1167 5210	-	4
422321	CFA.97 p-M10x20	388 1730	3627 16190	199 890	1333 5960	103 460	827 3690	-	4
422331	CFA.97 SH-10	276 1230	2343 10460	249 1110	1508 6730	114 510	918 4100	4	-
422332	CFA.97 CH-10	461 2060	3062 13670	235 1050	1089 4860	121 540	1066 4760	4	-
422341	CFA.97 B-M10-p-M10x20	388 1730	3627 16190	199 890	1333 5950	103 460	827 3690	-	4
422351	CFA.97 B-M10-SH-10	276 1230	2343 10460	217 970	1508 6730	114 510	921 4110	4	4
422352	CFA.97 B-M10-CH-10	461 2060	3062 13670	217 970	1089 4860	121 540	1066 4760	4	4
422361	CFA.97 p-M10x20-SH-10	276 1230	2343 10460	199 890	1333 5950	103 460	827 3690	4	4
422362	CFA.97 p-M10x20-CH-10	388 1730	3062 13670	199 890	1089 4860	103 460	827 3690	4	4